

The provision of public services
in the PRC:
Reconciling Market, State and Civil Society

Annex

to the paper presented by

Paolo Urio, Faculty of Economics & Social Sciences

Department of Political Science

International Symposium on Public Service and
Government Reform

Haikou, China, October 30-31, 2004

Figure 1

China's reforms, what is that?

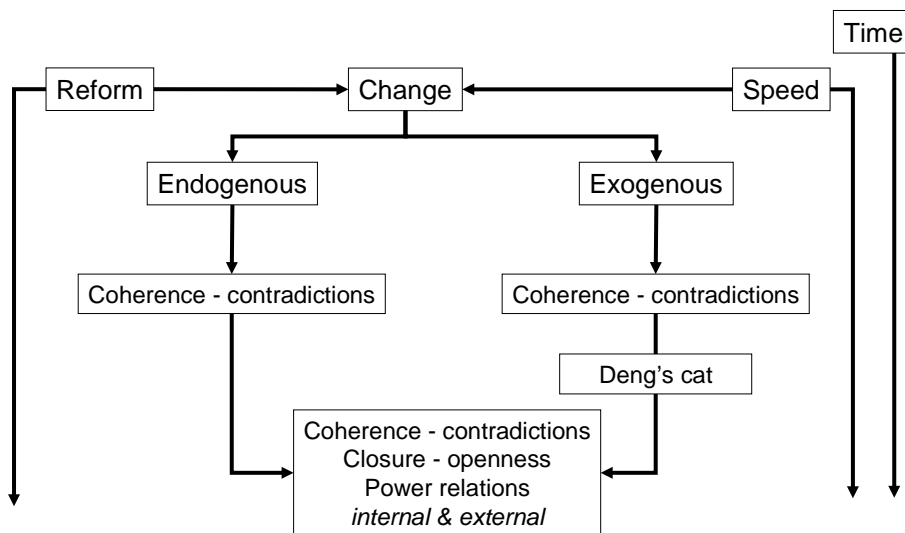

2

Figure 2

Remark - Questions

1. A system's components may change at different speeds
2. Can Deng's cat be socialist?
3. Can Deng's cat have Chinese characteristics?
4. Can Deng's cat have its own preferences?
5. In what kind of environment does Deng's cat prefer to live?
Foreseeable or unforeseeable environment?
6. Can Deng fully control his cat's behaviour?
(reference to the « *Bird Cage Economics* » of Chen Yun)

3

Figure 3

Some simple lessons from general systems theory: the concept of structural interdependence

1. If A changes, B changes
2. If A changes, there is a probability P that B will change
3. The P of a change in B depends on the size of A's change
4. The size of B's change depends on the size of A's change
5. Consequence: elements of a system may have different probabilities

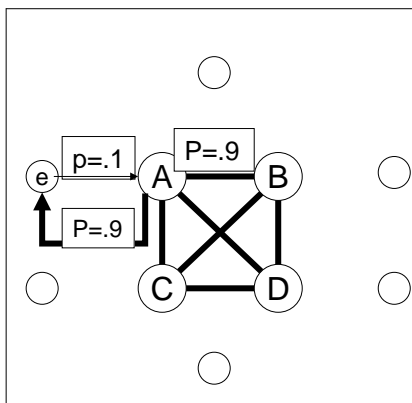

6. If this is the case, there will be some central elements with high P: **(A)**
- And some peripheral with low P: **(e)**

Question: What are the central elements of a social system?

1

Figure 4

The "functional imperatives"

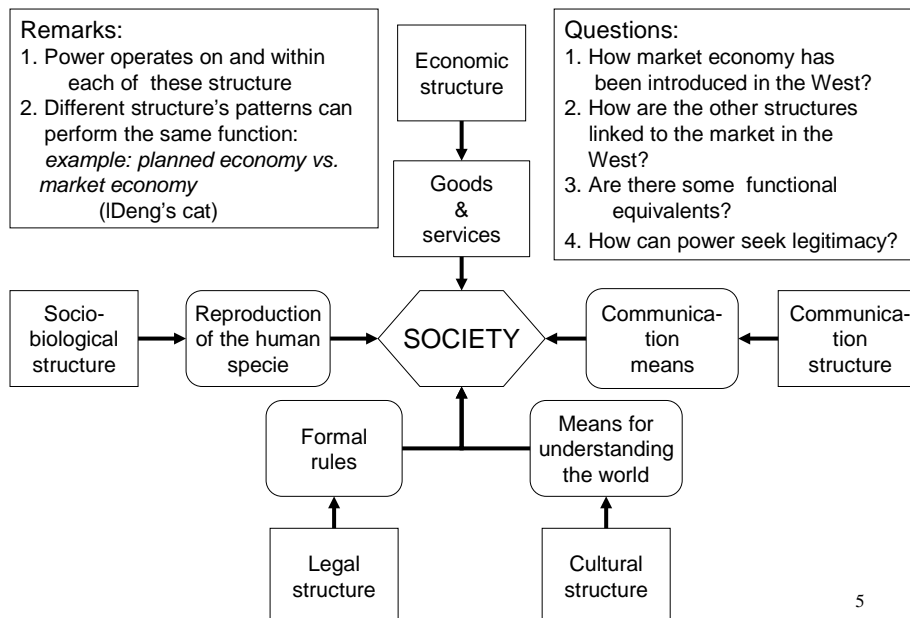

5

Figure 5

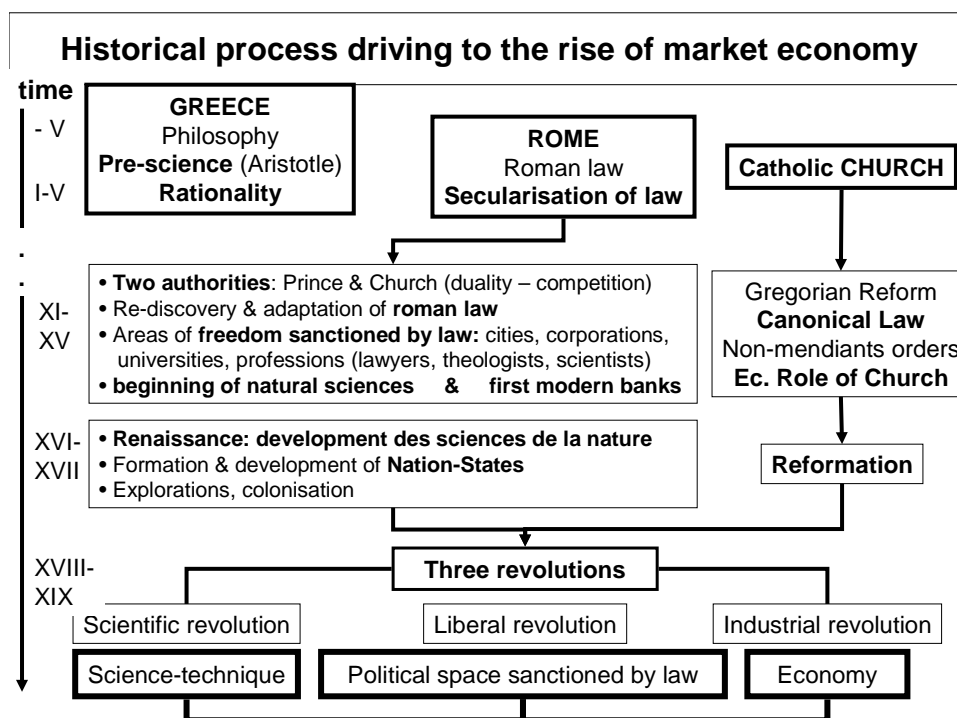

6

Figure 6

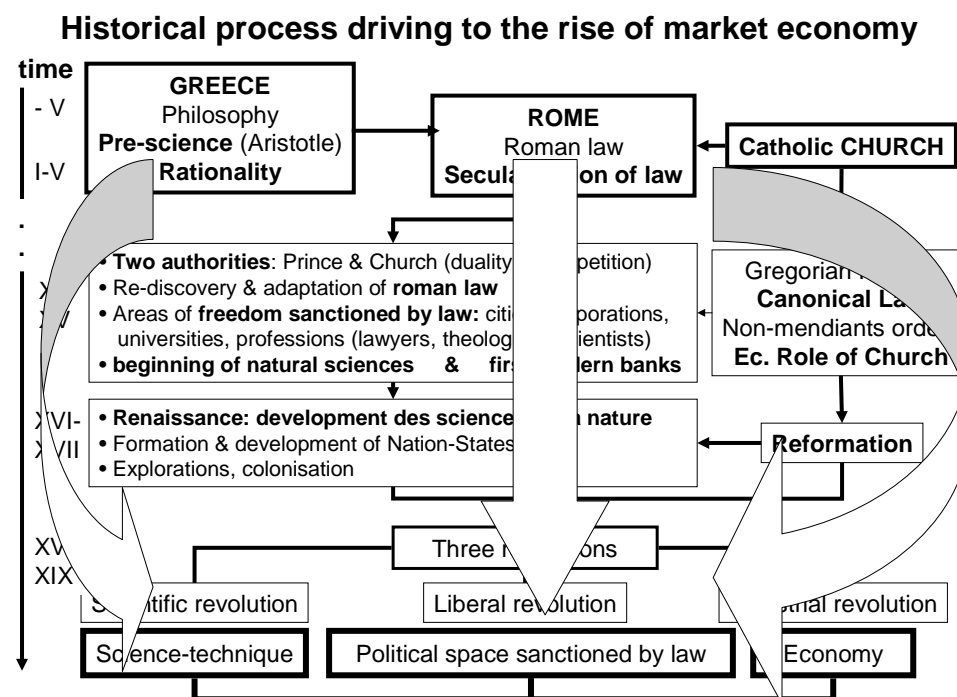

7

Figure 7

A simplified market economy supported by the Rule of Law

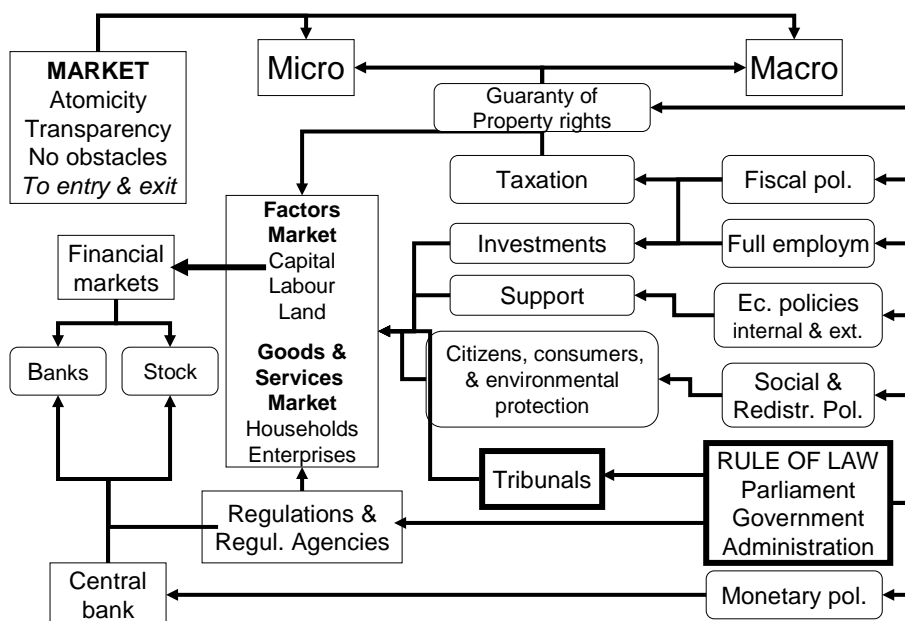

Figure 8

State, Market, Citizens and Groups in Western States

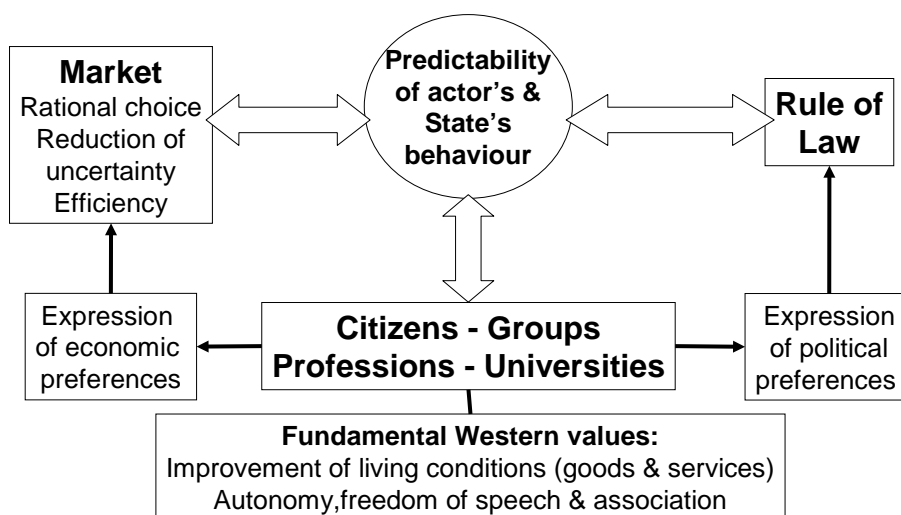

Figure 9

Major domains of Strategic management in PRC

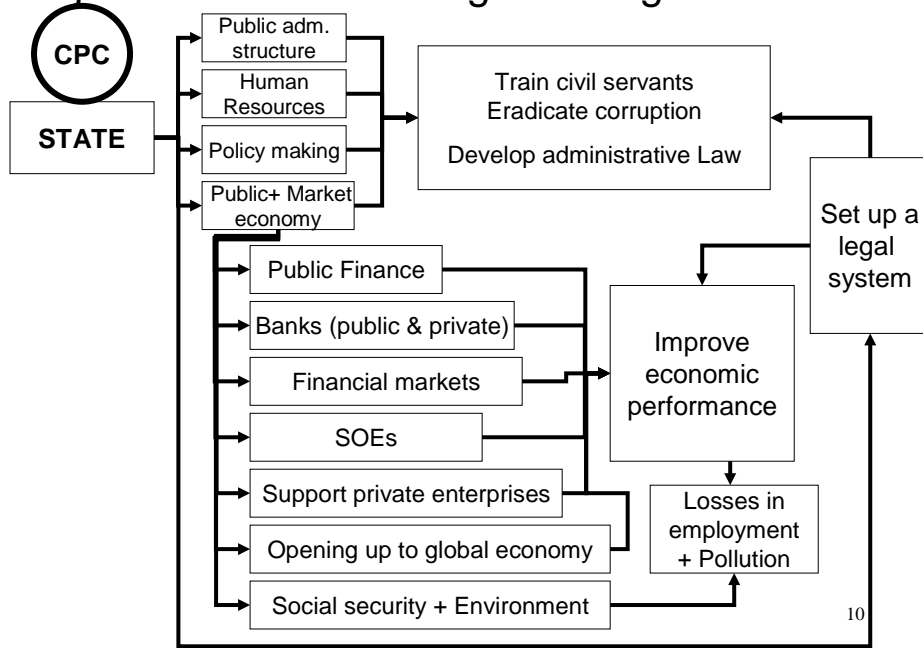

Figure 10

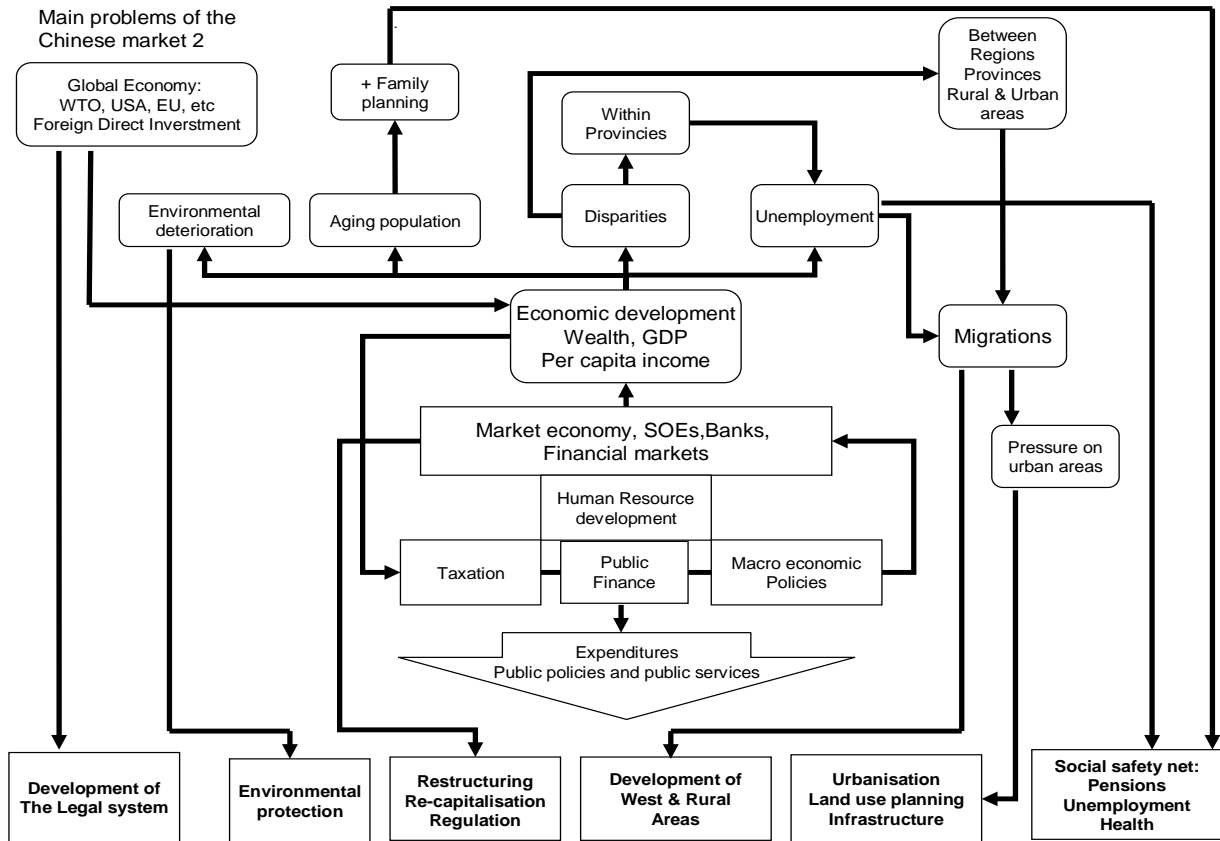
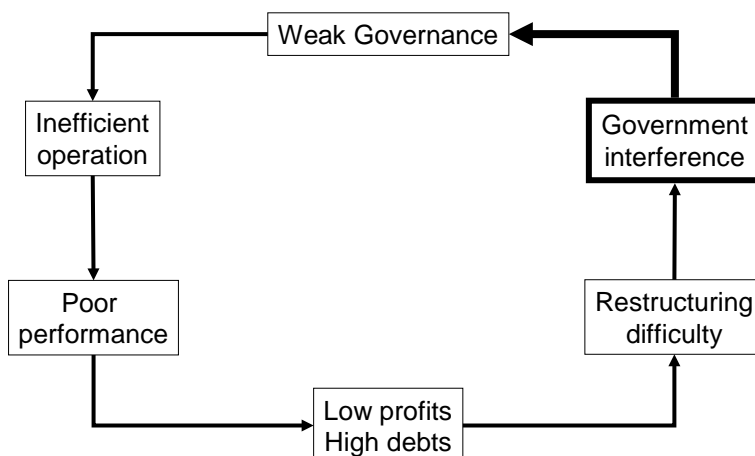

Figure 11

The vicious circle of poor enterprise performance

The vicious circle of poor enterprise performance



Source: adapted from OCDE, 2002

13

Figure 12

The vicious circles of banks and enterprise problems

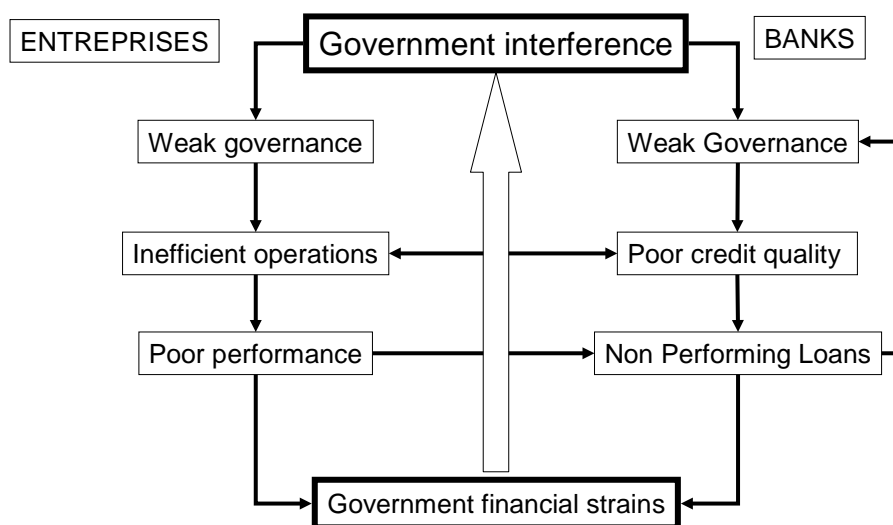

Source: adapted from OCDE, 2002

14

Figure13

The problems of the Legal System

Law – legal system – « rule of law » - « rule by law »

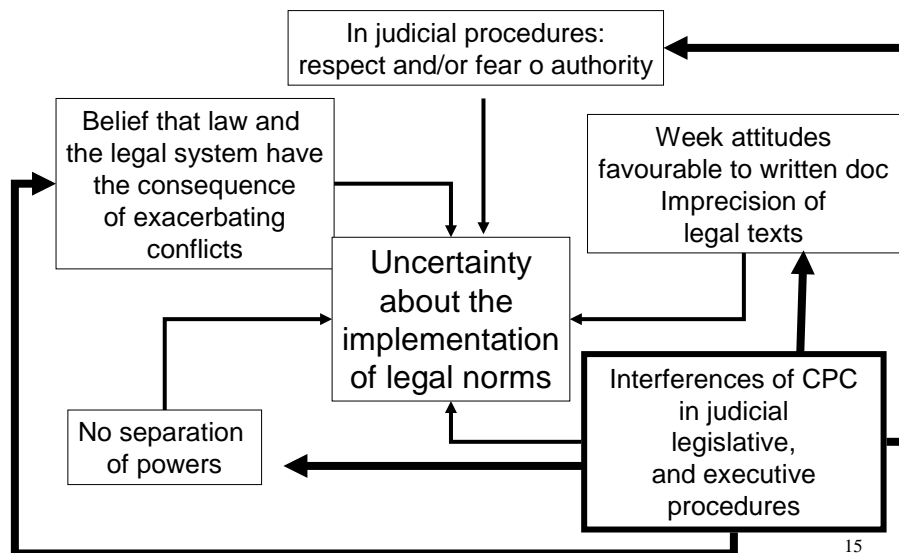

Figure 14

The problems of centre – periphery relations

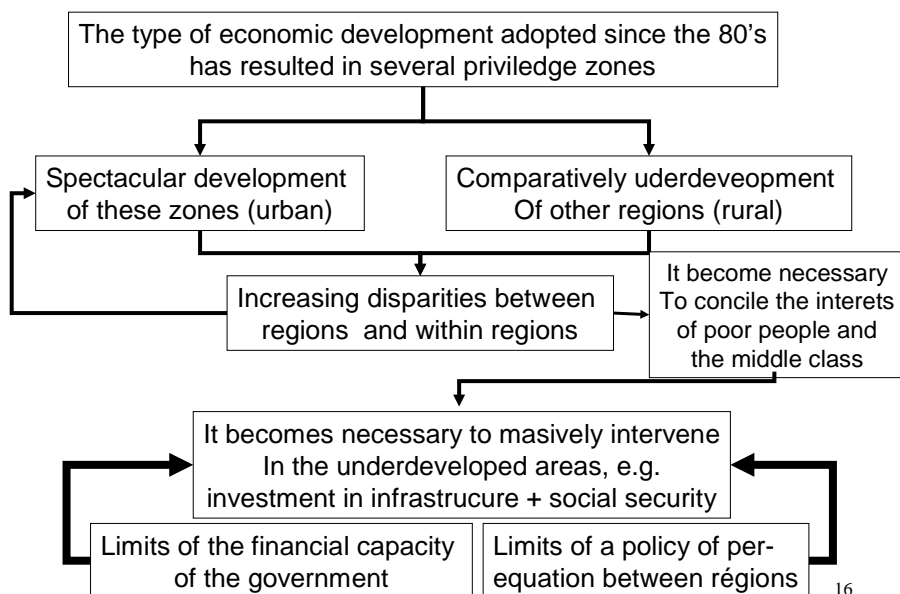
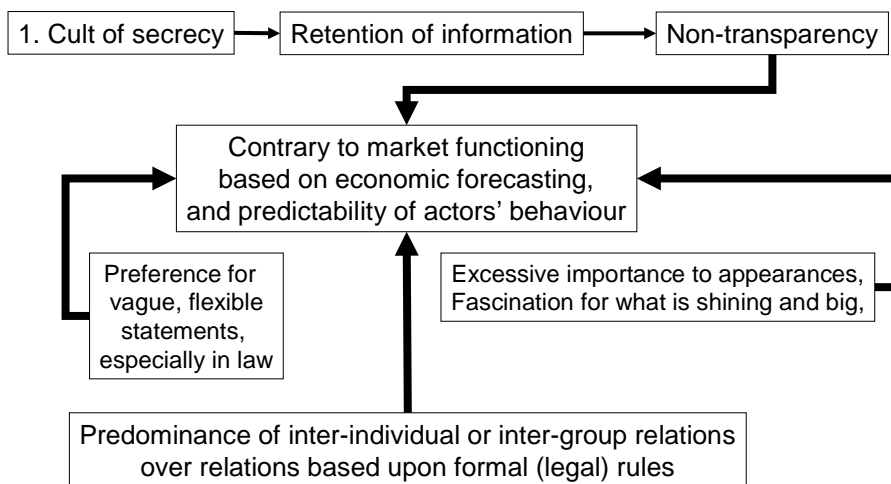

Figure 15

The problems of the cultural structure 1



17

Figure 16

The problems of the cultural structure 2

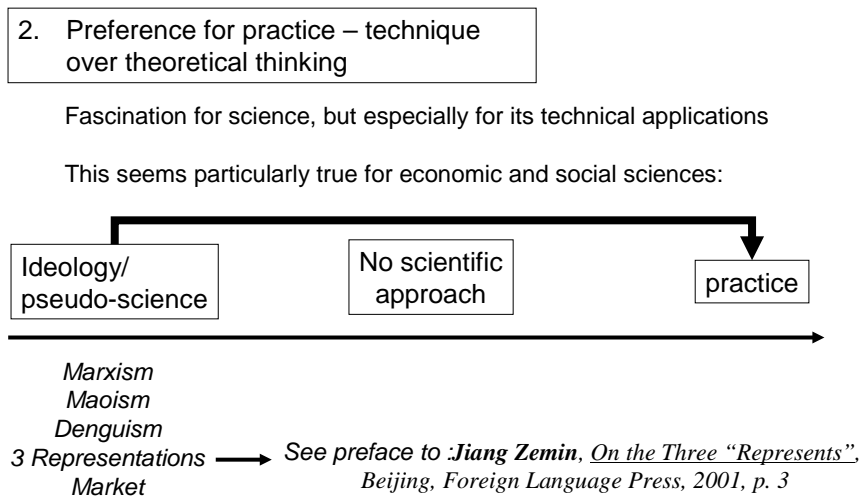

18

Figure 17

The problems of the cultural structure 3

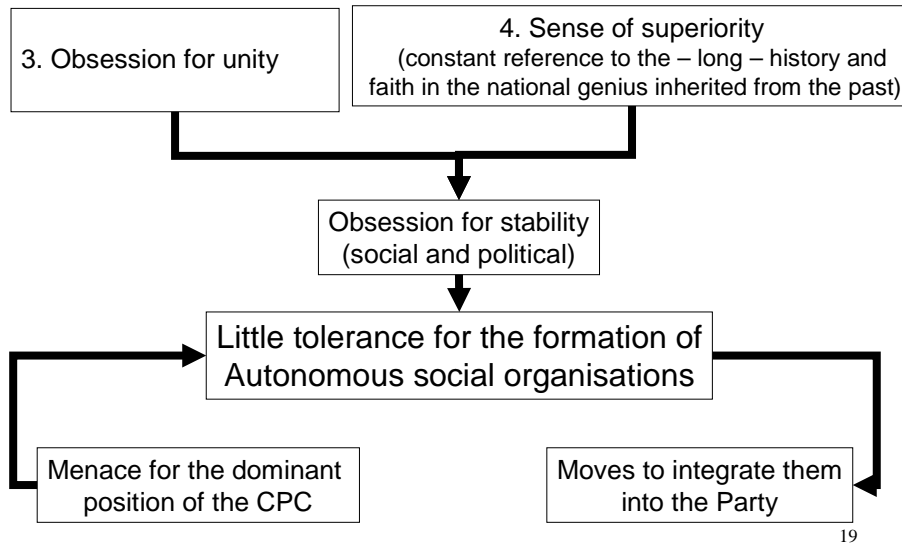

Figure 18

The problems of the cultural structure 4

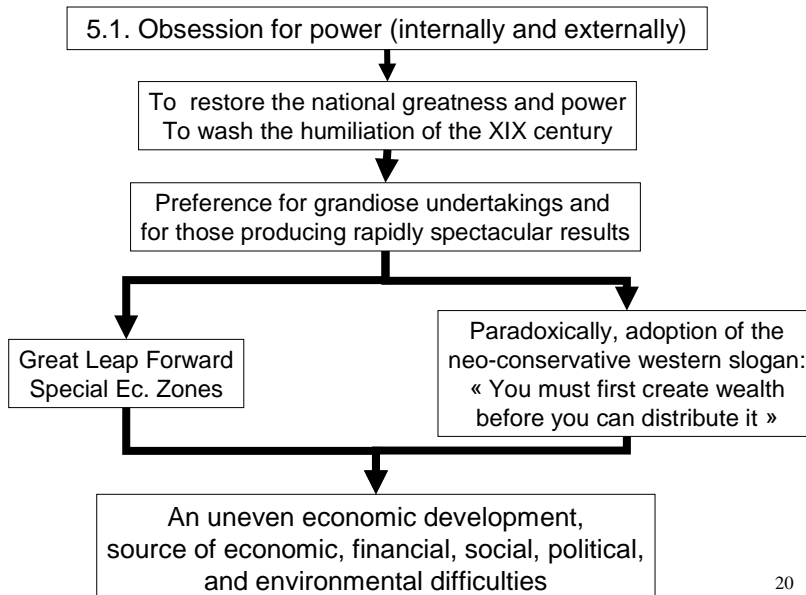
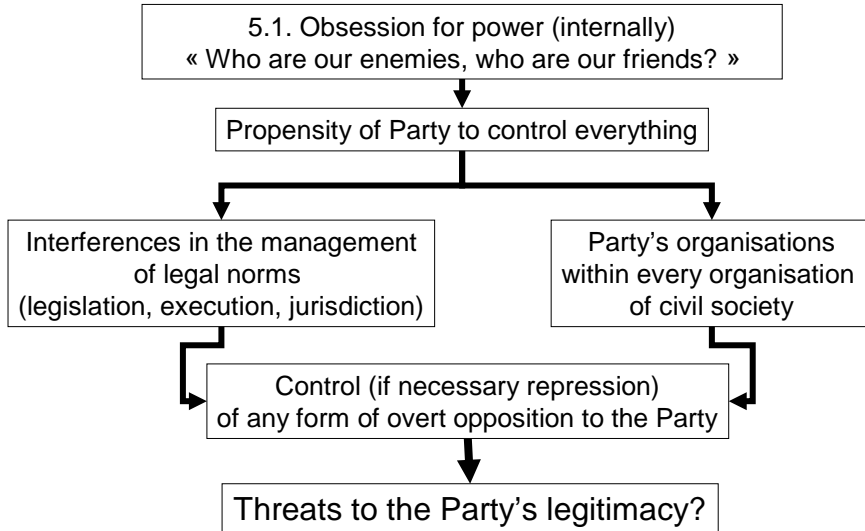

Figure 19

The problems of the cultural structure 5



21

Figure 20

The legitimating of power

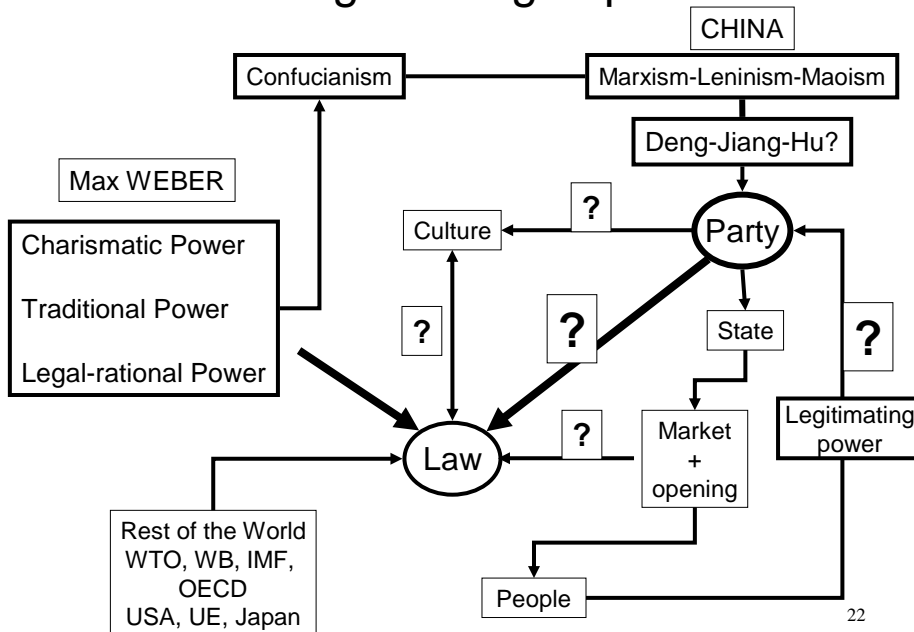

22

Figure 21

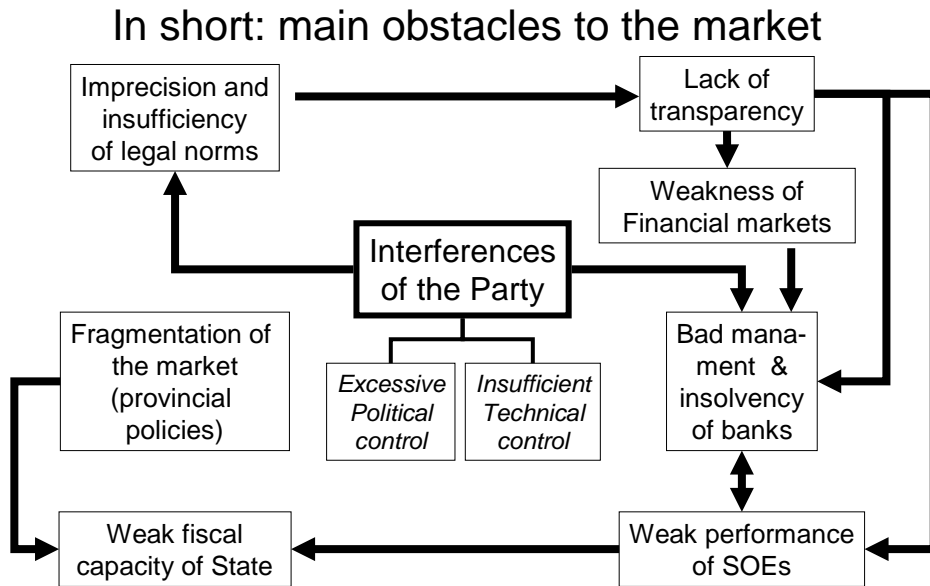

BUT, this does not necessarily mean that China will (inevitably and/or rapidly) organise its economy like a western market economy supported by a western-like rule of law».

Figure 22

Can China count on some sort of « functional equivalents » to the “Rule of Law”, in order to support the development of its market economy?

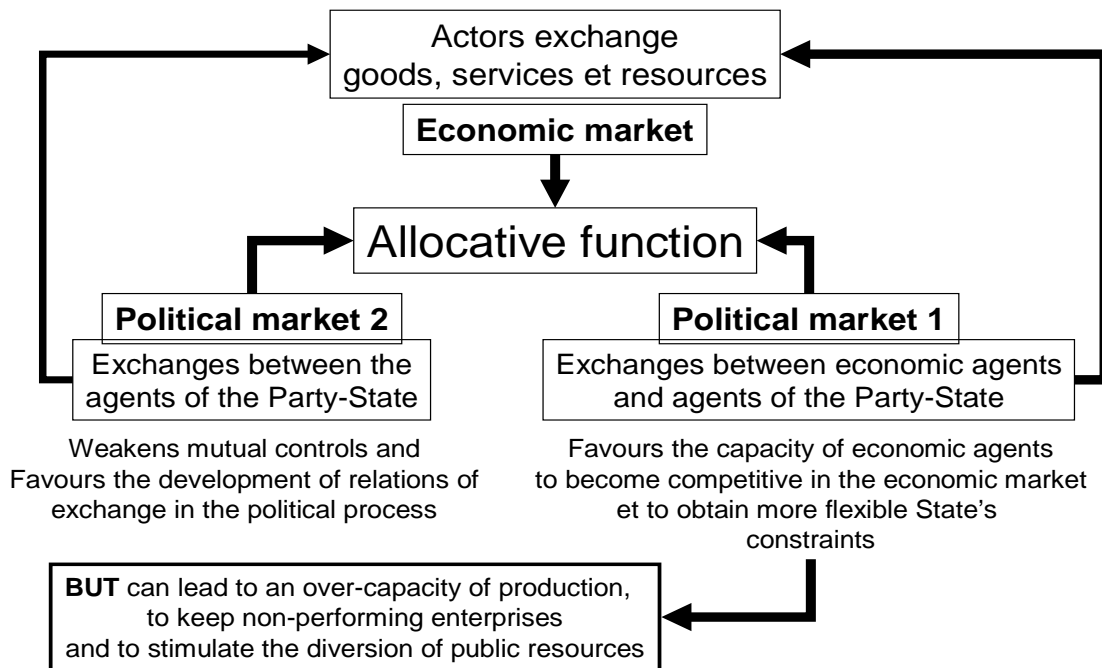

Yi-min Lin, *Between Politics and Markets*, Cambridge Univ. Press, 2001